



# 78M6610+LMU Evaluation Kit User Manual

**July 2013  
Rev. 1**

*Maxim Integrated cannot assume responsibility for use of any circuitry other than circuitry entirely embodied in a Maxim Integrated product. No circuit patent licenses are implied. Maxim Integrated reserves the right to change the circuitry and specifications without notice at any time.*

**Maxim Integrated 160 Rio Robles, San Jose, CA 95134 USA 1-408-601-1000**

© 2013 Maxim Integrated Products, Inc. Maxim Integrated and the Maxim Integrated logo are trademarks of Maxim Integrated Products, Inc.

## Table of Contents

<b>1</b>	<b>Introduction</b>	<b>4</b>
1.1	Ordering Information	4
1.2	Package Contents	4
1.3	System Requirements	4
1.4	Safety and ESD Notes	5
1.5	Testing the 78M6610+LMU EV Board Prior to Shipping	5
<b>2</b>	<b>USB Driver Installation</b>	<b>6</b>
2.1.1	Confirm COM Port Mapping	6
2.1.2	FTDI COM Port Trouble Shooting	6
<b>3</b>	<b>Hardware Setup: Sensor Interface</b>	<b>7</b>
3.1	Single-Phase Measurements using Shunts	7
3.1.1	Jumper and Switch Descriptions	8
3.1.2	Device Configuration	8
3.2	Single/Multiphase Measurements Using CTs	9
3.2.1	Jumper Position Changes	10
3.2.2	Device Configuration	10
3.3	Pseudo-Isolated Single-Phase Measurements Using CTs	21
3.3.1	Jumper Position Changes	23
3.3.2	Device Configuration	23
<b>4</b>	<b>Hardware Setup: Digital Interface</b>	<b>11</b>
4.1	USB Interface	11
4.2	RS-485 Interface	12
<b>5</b>	<b>Graphical User Interface (GUI)</b>	<b>13</b>
5.1	GUI Initialization	13
5.1.1	SSI Tab	13
5.1.2	Device Tab	14
5.1.3	Direct Tab	14
5.1.4	Configuration Tab	15
5.1.5	Command Register Tab	15
5.1.6	Calibration Tab	16
5.1.7	Power Tab	16
5.1.8	Energy Tab	17
5.1.9	Fundamental Tab	17
5.1.10	Min/Max Tab	17
5.1.11	Alarms Tab	18
5.1.12	Monitor Tab	19
<b>6</b>	<b>Hardware Design Information</b>	<b>24</b>
6.1	Board Schematics	24
6.2	Bill of Materials	28
6.3	PCB Layout	30
<b>7</b>	<b>Contact Information</b>	<b>32</b>
	<b>Revision History</b>	<b>32</b>

---

## Figures

Figure 1: 78M6610+LMU Evaluation Board Connections.....	7
Figure 2: 78M6610+LMU Evaluation Board Connections.....	9
Figure 2: 78M6610+LMU Evaluation Board Connections.....	22
Figure 3: 78M6610+LMU Evaluation Board Electrical Schematic (1 of 4).....	24
Figure 4: 78M6610+LMU Evaluation Board Electrical Schematic (2 of 4).....	25
Figure 5: 78M6610+LMU Evaluation Board Electrical Schematic (3 of 4).....	26
Figure 6: 78M6610+LMU Evaluation Board Electrical Schematic (4 of 4).....	27
Figure 7: 78M6610+LMU Evaluation Board PCB Top View .....	30
Figure 8: 78M6610+LMU Evaluation Board PCB Bottom View .....	31

## 1 Introduction

The 78M6610+LMU evaluation kit (EV kit) demonstrates the capability of the 78M6610+LMU for monitoring a single-phase or split-phase AC load using up to two voltages and two currents (sensors included). The EV kit connects to a PC through a USB cable that provides both power and data communication to the board. A Windows®-based graphical user interface (GUI) communicates with the device over a virtual for simplified access to measurement data and controls.

### 1.1 Ordering Information

PART	TYPE
78M6610+LMUEVK1#	Evaluation Kit

#Denotes a RoHS-compliant device that may include lead that is exempt under the RoHS requirements.

### 1.2 Package Contents

The 78M6610+LMU EV kit includes the following:

- 78M6610+LMU Evaluation Board
- Two 20A Current Transformers
- USB Cable Assembly USB A-B 28/24 1.8M (Tyco/Amp 1487588-3)
- CD with Documentation, GUI Application, and USB Drivers
- Calibration Coefficients Document (Hardcopy Only)

### 1.3 System Requirements

In addition to an AC source and load for measuring, the EV kit requires a Windows PC with the following features:

- 1GHz processor and 1GB RAM
- Minimum 1024 x 768 video display resolution
- Available USB port
- Microsoft Windows 7 or Windows XP®

*Windows and Windows XP are registered trademarks of Microsoft Corp.*

## 1.4 Safety and ESD Notes

**EXERCISE CAUTION WHEN LIVE AC VOLTAGES ARE PRESENT!**



Do not connect test equipment or external development boards directly to the non-isolated portion of the 78M6610 hardware. Damage to the 78M6610 and external equipment will occur due to the 78M6610's "high side" reference topology. The 78M6610's V3P3 supply (i.e., "high side") is connected directly to Neutral (Earth Ground) creating a ground reference disparity with any properly grounded external equipment.

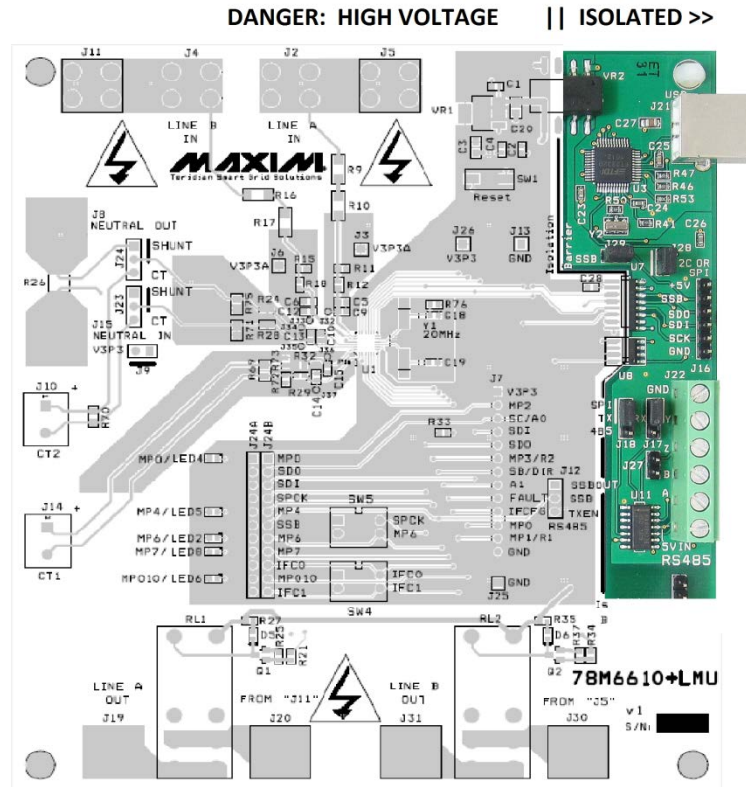

The board components and firmware settings are designed to operate with the following nominal AC electrical ranges:

Voltage	Current	Line Frequency
10-300 VAC	10 mA – 20A	46-64 Hz

## 1.5 Testing the 78M6610+LMU EV Board Prior to Shipping

Before every kit is shipped, the board (and sensors) undergo a single-load point calibration using precise energy source equipment. The device temperature is also calibrated at the same time. Results printed out on paper and included with the EV kit.

## 2 USB Driver Installation

This EV kit includes an isolated USB interface for serial communications with a PC. The FTDI USB controller IC FT2232 performs the USB functions. The FTDI Windows driver presents a virtual COM port for enabling serial communications. The FTDI Windows driver is a certified driver for Windows XP and Windows 7.

Upon attaching the 78M6610+LMU EV Board to the PC, the **Found New Hardware Wizard** automatically launches and installs the appropriate driver files. If your PC does not find the FTDI driver files on its local hard disk drive, locate and reference the FTDI USB Driver and Utilities subdirectory on the CD. The FT2232 controller and 78M6610+LMU is powered from the USB cable and is active when no AC power is applied to the sensor interface of the 78M6610+LMU EV Kit.

**Note:** If an older FTDI driver has been previously installed, it is recommended to remove the older version before installing this newer FTDI driver. Execute the **ftdiClean.exe** utility from the FTDI USB Driver and Utilities subdirectory. For FTDI driver support on other operating systems, refer to the FTDI website at [www.ftdichip.com](http://www.ftdichip.com).

### 2.1.1 Confirm COM Port Mapping

- Launch the **Control Panel** and click on the **System** icon.
- The **System Properties** screen appears. Click on the **Hardware** tab. Click on **Device Manager**. Under **Ports (COM & LPT)**, look for the **USB Serial Port** assignment.
- Take note of the COM port assignment for the USB Serial Port.

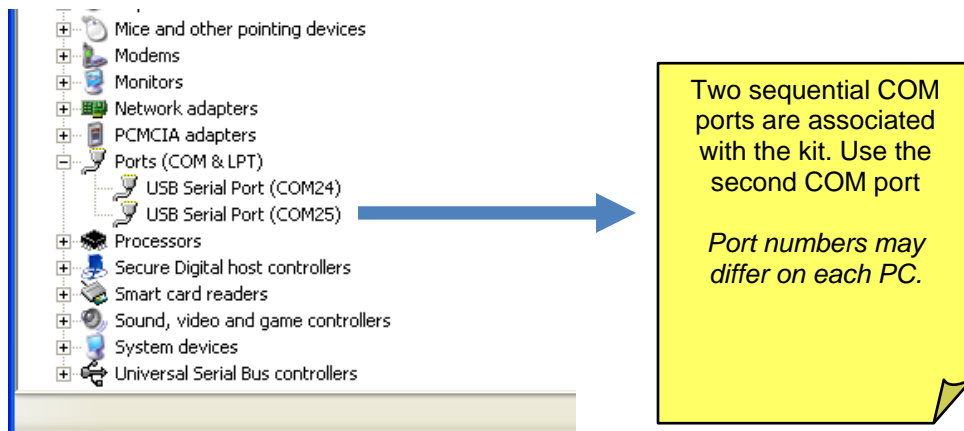

### 2.1.2 FTDI COM Port Trouble Shooting

If the FTDI device driver did not install properly, there would be no assigned COM port number for the FTDI controller. Repeat the USB Driver Installation, see [Section 2.1](#).

Microsoft Windows may associate a Ball Point device to the FTDI USB controller. When this occurs a FTDI device COM port assignment is available via HyperTerminal but there is no communications data. Verify if a Ball Point device has been added to the "Human Interface Devices" via the Device manager. See [Section 2.1.1](#) for access to the Device Manager. If a Ball Point device exists, delete it and unplug and replug the EV Kit's USB cable.

### 3 Hardware Setup: Sensor Interface

The 78M6610+LMU EV board can be provisioned in multiple configurations. This manual covers common setups for using a shunt, shunt with CT, or two CTs. The board is provisioned and calibrated for the following configuration to retrieve the gain value of the shunt (printed on a label located on the bottom of the board).

#### 3.1 Simple 2-Wire Single-Phase Measurements Using Shunts

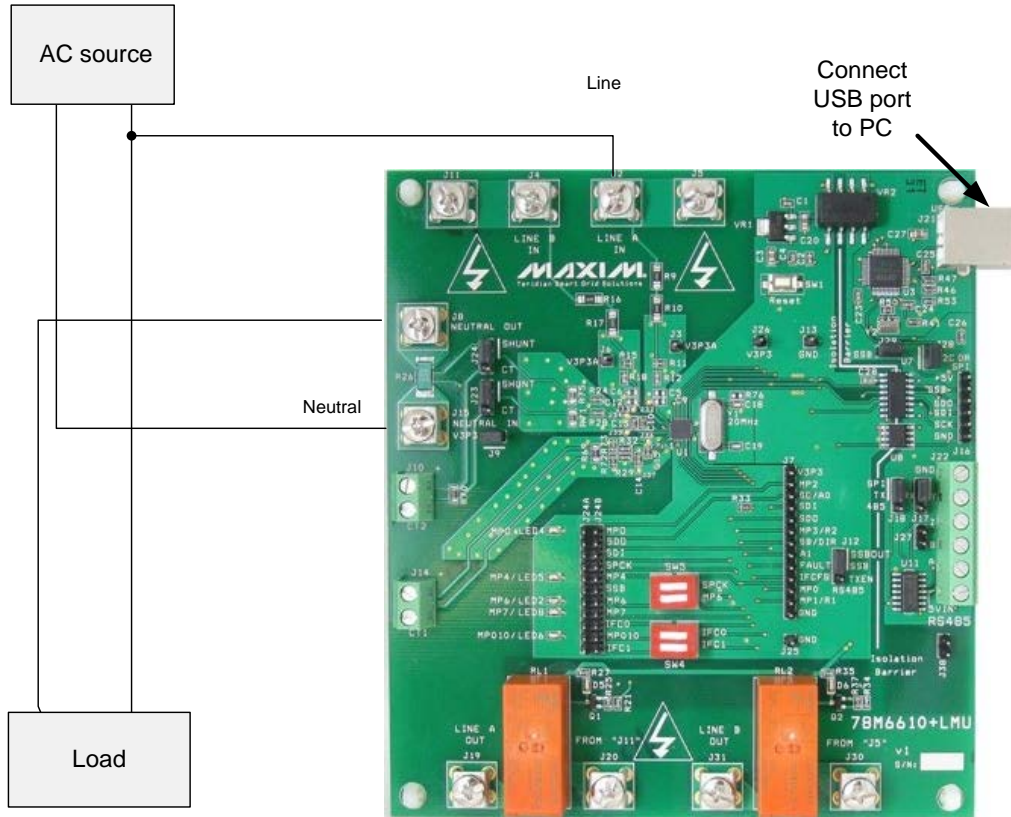

**Figure 1: 78M6610+LMU Evaluation Board Connections**

1. Connect the AC source Neutral output to J15.
2. Connect J8 to Load's Neutral input.
3. Connect the AC source Line 1 output to J2 and to Load's Line 1 input.

### 3.1.1 Jumper and Switch Descriptions

The following tables describe the default position of the EV board jumpers and switches for using the on-board shunt current sensor at sensor slot S1.

#### J23 Jumper Description

J23 Pins	Description	Jumper
1/2	Connect J15 SHUNT to 78M6610+LMU Sensor Slot 1	Installed
2/3	Connect J10 CT2+ to 78M6610+LMU Sensor Slot 1	-

#### J24 Jumper Description

J24 Pins	Description	Jumper
1/2	Connects J8 SHUNT to 78M6610+LMU Sensor Slot 1	Installed
2/3	Connects J10 CT2- to 78M6610+LMU Sensor Slot 1	-

#### J9 Jumper Description

J9 Pins	Description	Jumper
1/2	Connect AC Neutral to V3P3A (chip reference)	Installed

### 3.1.2 Device Configuration

Use the Configuration tab to map the sensors as shown in the table below. Re-enter the gain value, as needed, for the shunt resistor into the S1\_GAIN register.

Voltage			Current		
VA	S0	0	IA	S1	0
VB			IB		
VC			Pre-Amp	1X S1	



### 3.2 Single/Multiphase Measurements Using CTs

In this diagram, the on-board relays are also wired in series to demonstrate load control.

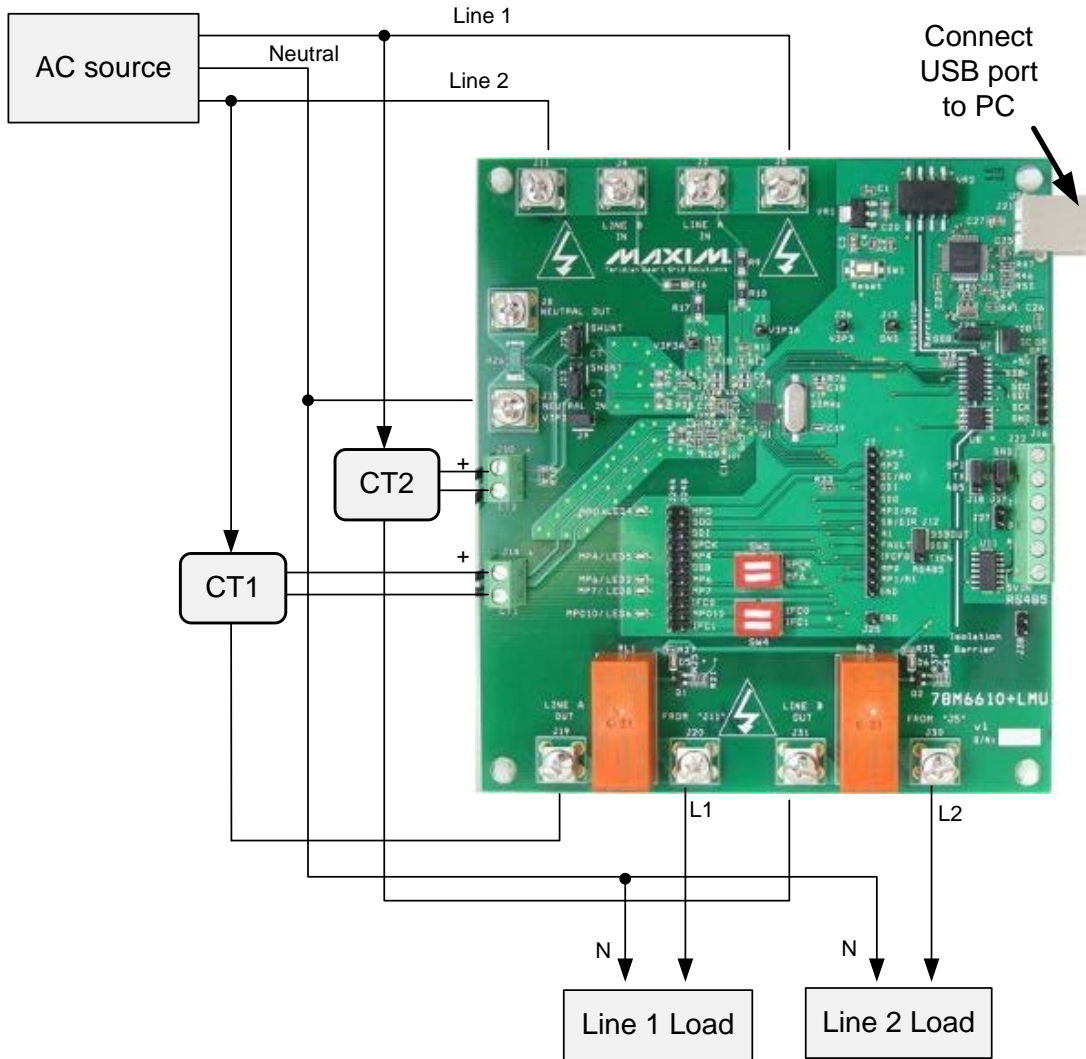

**Figure 2: 78M6610+LMU Evaluation Board Connections**

1. Connect the AC source Neutral to J15 and the load(s).
2. Connect the AC source Line 1 to J2 and to J19 (Relay1) through the Line 1 CT.
3. Connect J20 (Relay1) to Line 1 load.
4. Connect Line 1 CT's secondary to J14 (burden resistor).
5. Connect the AC source Line 2 to J4 and to J31 (Relay2) through the Line 2 CT.
6. Connect J30 (Relay1) to Line 1 load.
7. Connect Line 2 CT's secondary to J10 (burden resistor).

### 3.2.1 Jumper Position Changes

Move J23 and J24 jumpers to position CT to use CT2 for sensor slot S1.

#### J23 Jumper Description

J23 Pins	Description	Jumper
1/2	Connect J15 SHUNT to 78M6610+LMU Sensor Slot 1	-
2/3	Connect J10 CT2+ to 78M6610+LMU Sensor Slot 1	Installed

#### J24 Jumper Description

J24 Pins	Description	Jumper
1/2	Connects J8 SHUNT to 78M6610+LMU Sensor Slot 1	-
2/3	Connects J10 CT2- to 78M6610+LMU Sensor Slot 1	Installed

#### J9 Jumper Description

J9 Pins	Description	Jumper
1/2	Connect AC Neutral to V3P3A (chip reference)	Installed

### 3.2.2 Device Configuration

Use the Configuration tab to map the sensors as shown in the table below. Re-enter the gain value as needed for CT2 into the S1\_GAIN register.

Voltage			Current		
VA	S0		IA	S1	0
VB	0	S2	IB	0	S3
VC	S0	-S2	Pre-Amp	1X S1	1X S3

**Note:** The values for VC will not be displayed correctly on the **Power** tab of the provided GUI due to the increased full-scale value of VC. Reported results for measurements derived from VC will be one-half the expected magnitude.

## 4 Hardware Setup: Digital Interface

### 4.1 Isolated USB Interface

#### Switch Description

	Description	Default
SW4	Sets host interface mode upon reset	IFC0 Open IFC1 Closed
SW5	Sets device address upon reset (UART/I <sup>2</sup> C modes)	Both Closed

#### J12 Jumper Description

J12 Pins	Description	Default
1/2	Connect 78M6610+LMU to USB Controller (U3)	Installed
2/3	Connect 78M6610+LMU to RS485 transceiver (U11)	-

#### J17 Jumper Description

J17 Pins	Description	Default
1/2	Connect USB Controller to isolation IC (U7)	Installed
2/3	Connect RS485 transceiver to isolation IC (U7)	-

#### J18 Jumper Description

J18 Pins	Description	Default
1/2	Connect USB Controller to isolation IC (U7)	Installed
2/3	Connect RS485 transceiver to isolation IC (U7)	-

#### J24A, J24B Jumper Description

J24A/B Pins	Description	Default
1/1	Connects MP0 to LED4	Installed
2/2	SDO/TXD/SDA <sub>o</sub>	-
3/3	SDI/RXD/SDA <sub>i</sub>	-
4/4	SPCK/ADDR0	-
5/5	Connects MP4 to LED5	Installed
6/6	SSB/DIR/SCL	-
7/7	Connects MP6/ADDR1 connection to LED2	Installed
8/8	Connects MP7 connection to LED8	Installed
9/9	IFC0	-
10/10	Connects MP10 connection to LED6	Installed
11/11	IFC1	-

**J27 Jumper Description**

J27 Pins	Description	Default
1/2	Enable on-board RS485 termination resistor	-

**J28 Jumper Description**

J28 Pins	Description	Default
1/2	Connect USB Controller to isolation IC (U7)	Installed

**J29 Jumper Description**

J29 Pins	Description	Default
1/2	Connect USB Controller to isolation IC (U7)	Installed

**J38 Jumper Description**

J38 Pins	Description	Default
1/2	Enable on-board RS485 termination resistor	-

**4.2 Isolated RS-485 Interface**

The board also includes an isolated RS-485 interface as an alternative to the USB interface. The 78M6610+LMU serial UART is connected to the RS-485 transceiver. Refer to the IC data sheet for details on the serial protocol.

- Move J12, J17, and J18 jumpers from position 1-2 to position 2-3 to connect the RS-485 transceiver instead of the USB controller.

The USB cable provides power to the EV board when connected to the PC. If the USB cable not being used +5VDC power must be provided at J16, pins 1 and 6 (+5V and ground, respectively). Do not supply power to JJ16, pin1 AND connect the USB cable to the PC.

**J22 RS-485 Connector Pin Assignment**

J22 Pin Number	Pin Name	Pin Description
1	+5VDC	Connect to external source
2	Data - P	Tri-state, Bi-directional
3	Data - N	Tri-state, Bi-directional
4	GND	Connect to external source

**4.3 Isolated UART, I<sup>2</sup>C, SPI Interfaces**

The native host interfaces of the 78M6610+LMU are made available on the isolated side of the barrier at J16.

## 5 Graphical User Interface (GUI)

A graphical user interface (GUI) is included on the 78M6610+LMU EV kit CD to facilitate quick evaluation of the 78M6610+LMU energy measurement device. The GUI requires Microsoft.NET Framework 4 on the PC for which the GUI is to execute on. Upon invoking the GUI executable file, an installation wizard may appear if Microsoft.NET Framework 4 is not installed on the PC. Follow the installation wizard instructions, or download Microsoft.NET Framework 4 from the Microsoft website prior to launching the GUI.

### 5.1 GUI Initialization

The GUI is self-explanatory when used with the *78M6610+LMU Data Sheet*. The user, however, should note the following about the EV kit hardware:

- Serial COM Port:
  - Following the installation instructions in Section 2, launch the GUI executable. Click the **Connection** pull-down menu and select **Connect**.

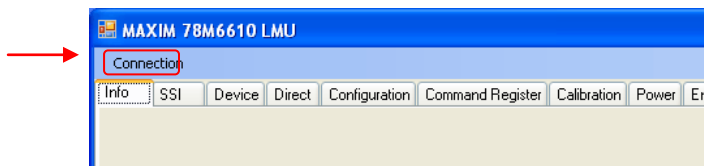

- The **COM Port / Baud Rate** box appears. Select the COM port assigned to the EV kit and leave the baud rate set to 38400 (default). Click the **Connect** button.

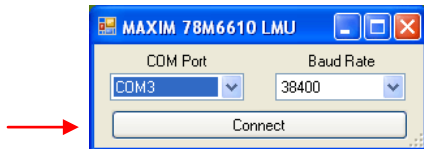

#### 5.1.1 SSI Tab

- SSI ID:
  - Click the **SSI** tab. Use the SSI ID number set by DIP switch 5 (1 and 2 are closed by default) and click **Set Target**. Upon successful communication with the EV kit, a message appears in the message box.



### 5.1.2 Device Tab

The **Device** tab shows to current firmware build as well as the temperature and line frequency being measured.

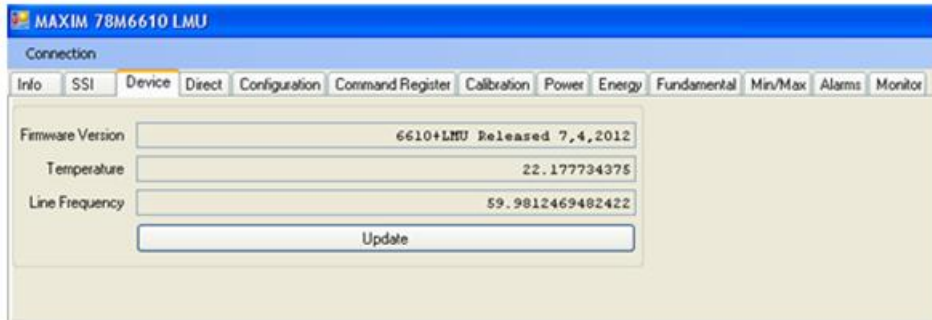

### 5.1.3 Direct Tab

The **Direct** tab allows read and write access to all the byte-addressable registers documented in the data sheet. The data can be displayed with the scale factor and units applied for convenience. In the example below, the voltage register is being read, so the volts option is used to display the data.

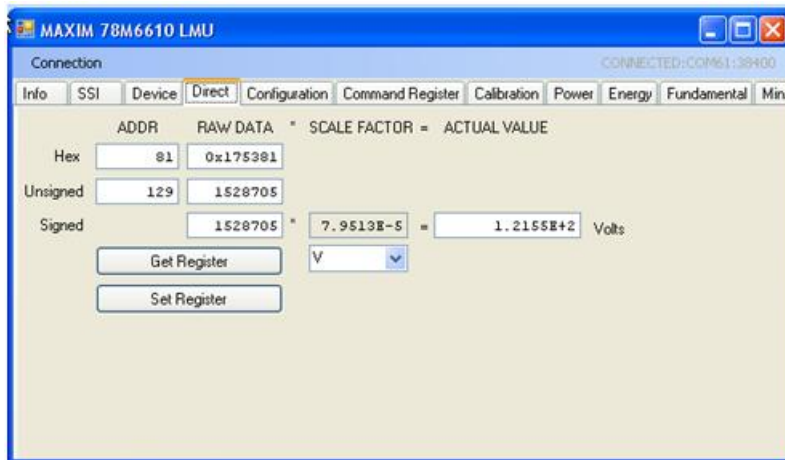

### 5.1.4 Configuration Tab

The **Configuration** tab is used to set up the sensor interface. Once this is done it can be saved to NVRAM for future use, or programmed to a user-defined configuration and saved. See the **Calibration** tab for saving the settings.

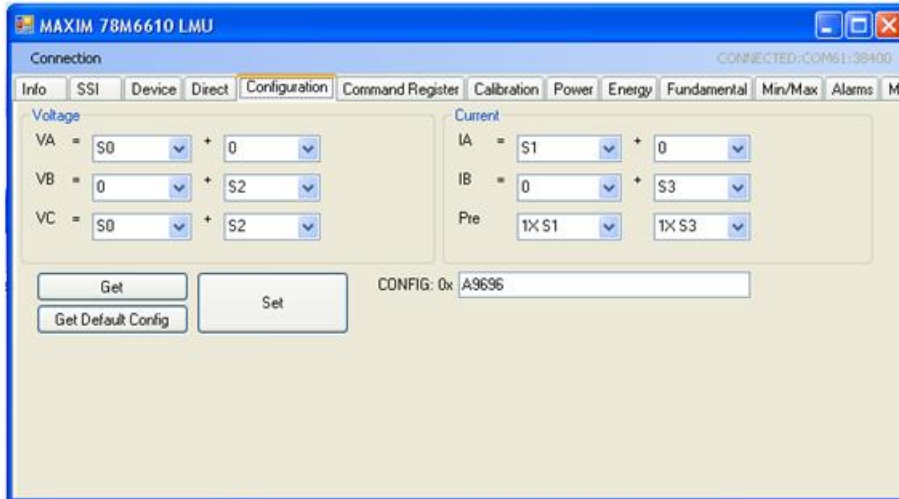

### 5.1.5 Command Register Tab

The **Command Register** tab is a read/write control tab for manual operation of the command register (0x00). Hex and decimal formats are supported.

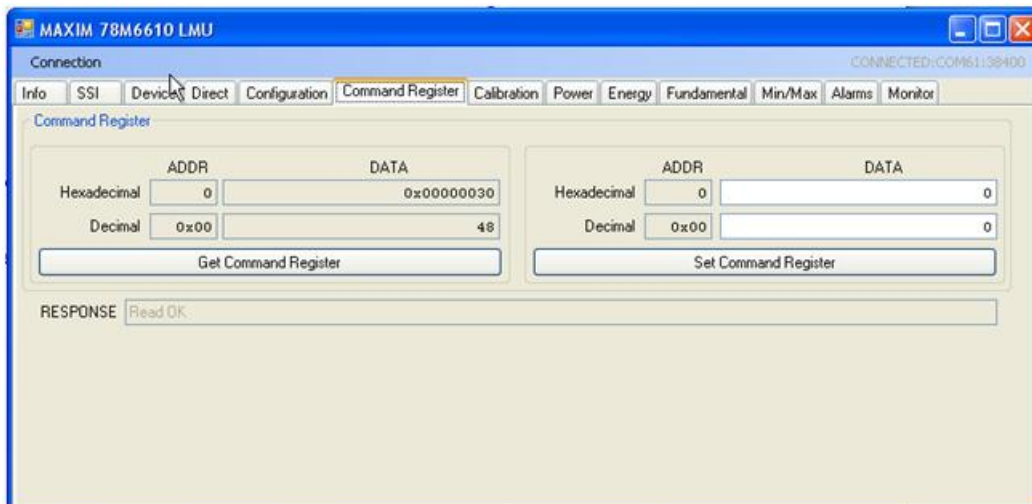

### 5.1.6 Calibration Tab

The **Calibration** tab is used to configure and execute calibration commands. The calibration targets can be viewed and changed and the scaling parameters are also displayed for convenience.

The calibration and NVRAM are also saved using the provided button.

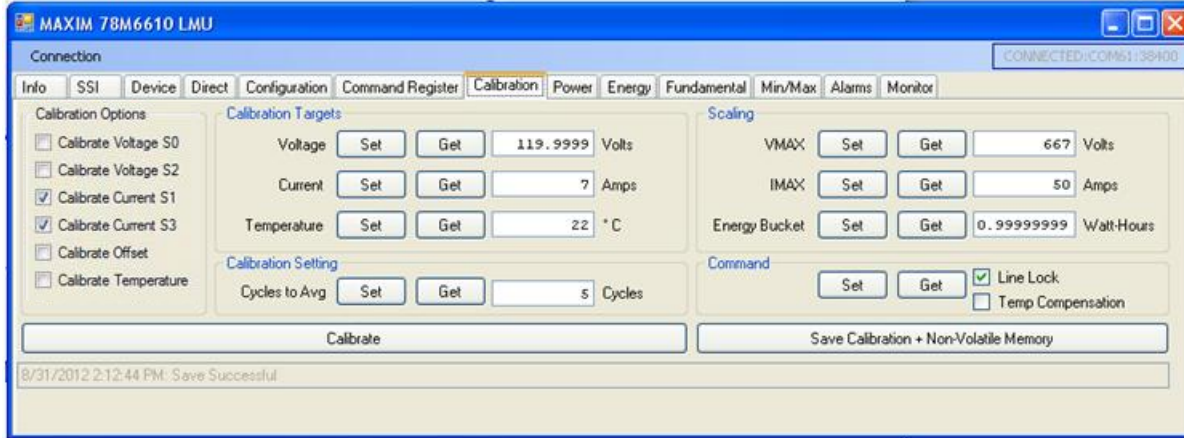

### 5.1.7 Power Tab

The **Power** tab displays the current power being consumed by the loads. P (active power), Q (reactive power), and S (apparent power) are displayed along with the voltage, current, crest factor, and power factor are also displayed.

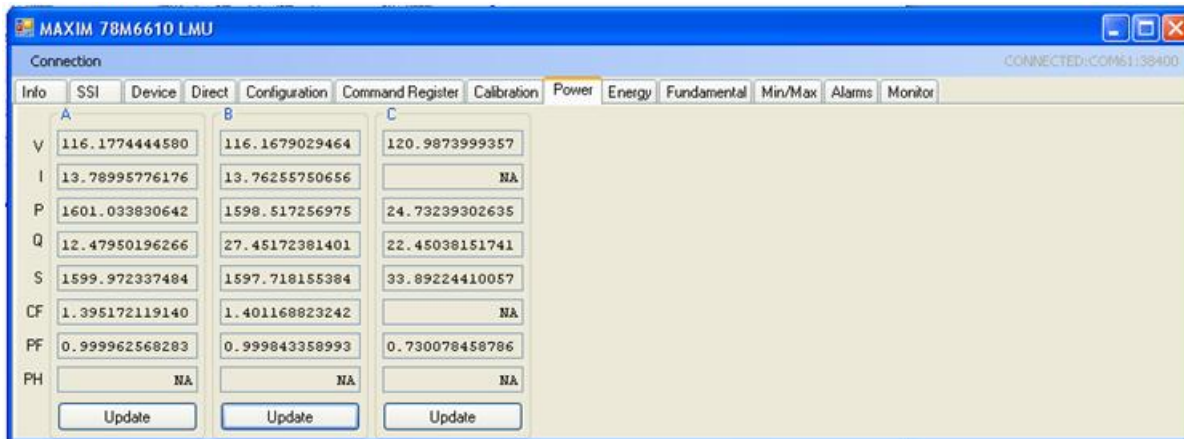



### 5.1.8 Energy Tab

The **Energy** tab displays the accumulated power both into and out of the load. The pull-down menu is used to select the channel that is being displayed; A, B, or C, and update is used to update the displayed data

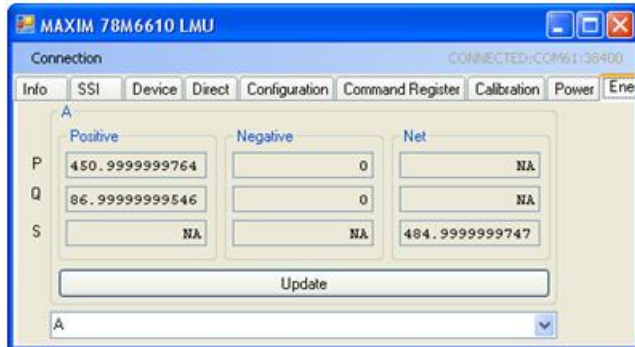

### 5.1.9 Fundamental Tab

The **Fundamental** tab is used to display the fundamental and harmonic measurements for voltage, current, and power. The harmonics displayed can be selected with the get/set harmonic buttons.

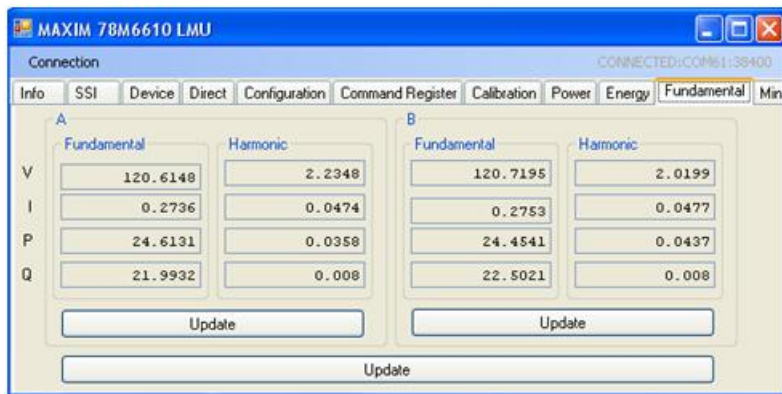

### 5.1.10 Min/Max Tab

The **Min/Max** tab is used to display the minimum and maximum measurements for the parameters selected in the **Word Addr** column. The units can be selected with the provided pull-down menu and the most recent measurements are updated using the get buttons. All the measurements are reset with the reset button.

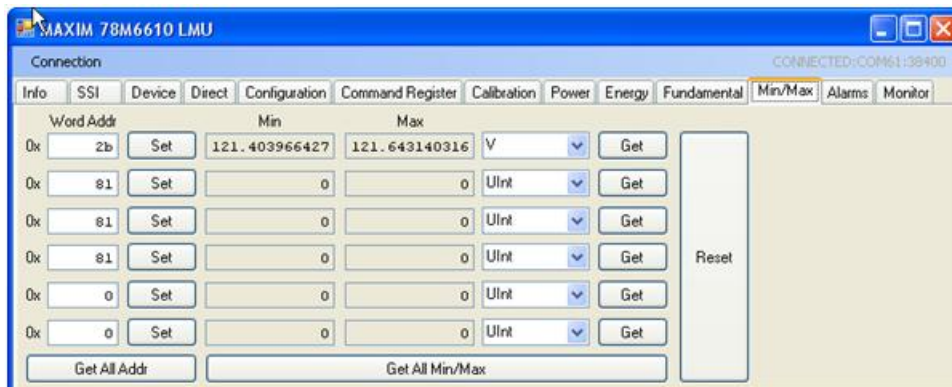

### 5.1.11 Alarms Tab

The **Alarms** tab is a user-definable display of whatever parameters are required in a particular application. The alarms are described in detail in Sections 2.11 and 2.12 of the *78M6610+LMU Data Sheet*.

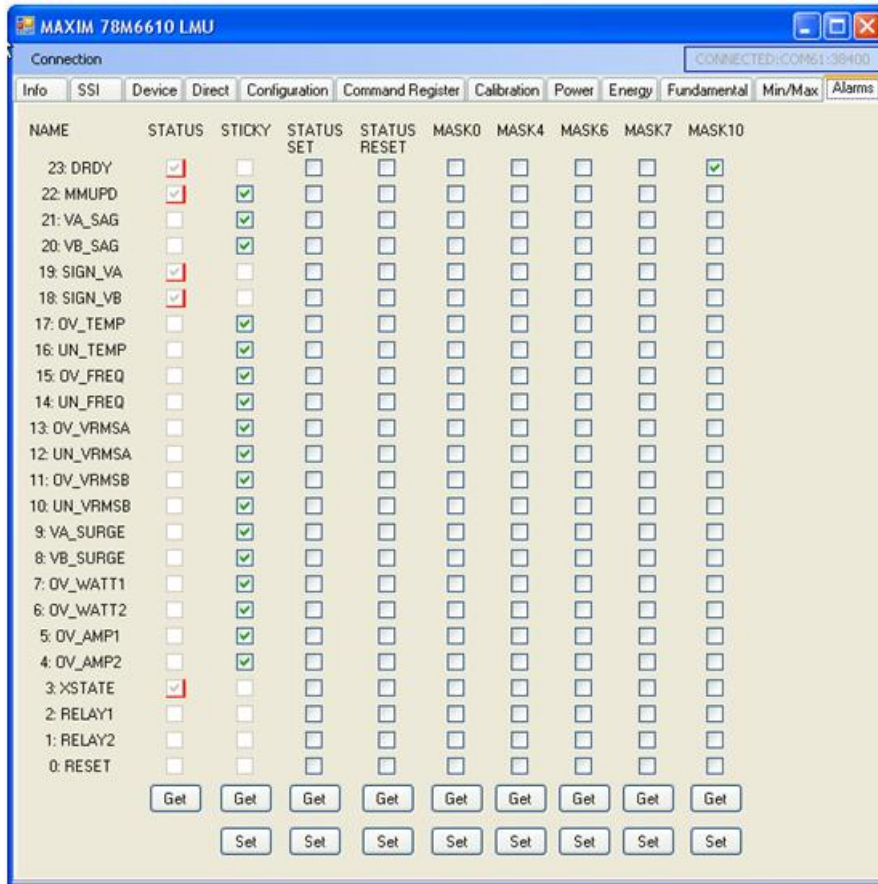

### 5.1.12 Monitor Tab

The **Monitor** tab is a running record of all the communications between the GUI and the target 78M6610+LMU. A log file can be generated to save the transactions for later analysis.

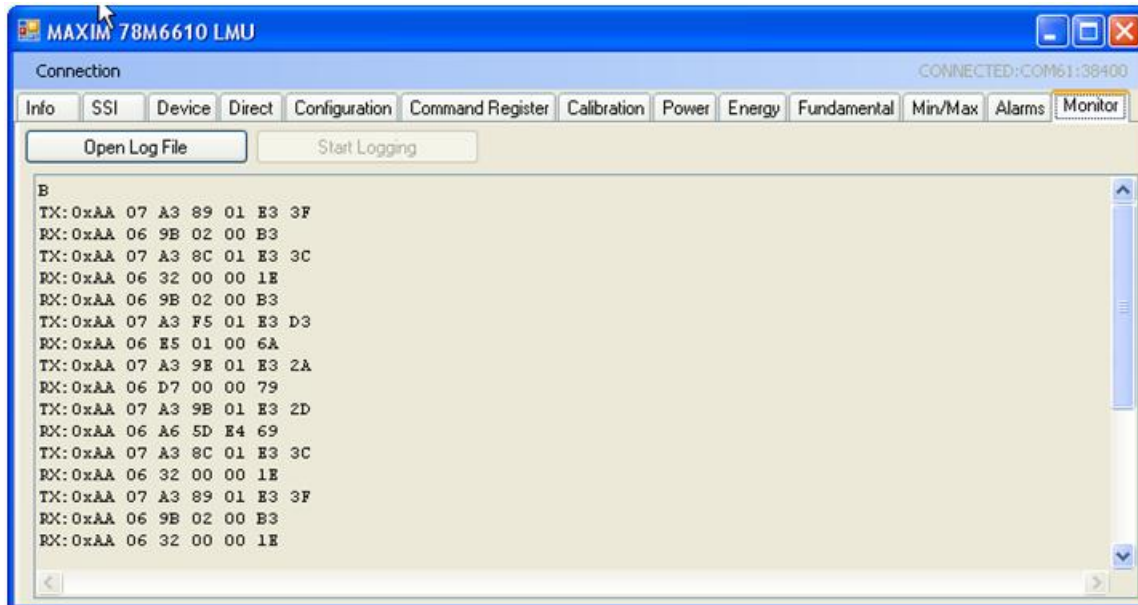

## 6 Alternate Sensor Configurations

### 6.1 Split-Phase Using Shunt (On Neutral) and One CT (On Line)

In this configuration, neutral is measured instead of Line 2. Results for Line 2 are indirectly calculated from the measurements on Line 1 and Neutral.

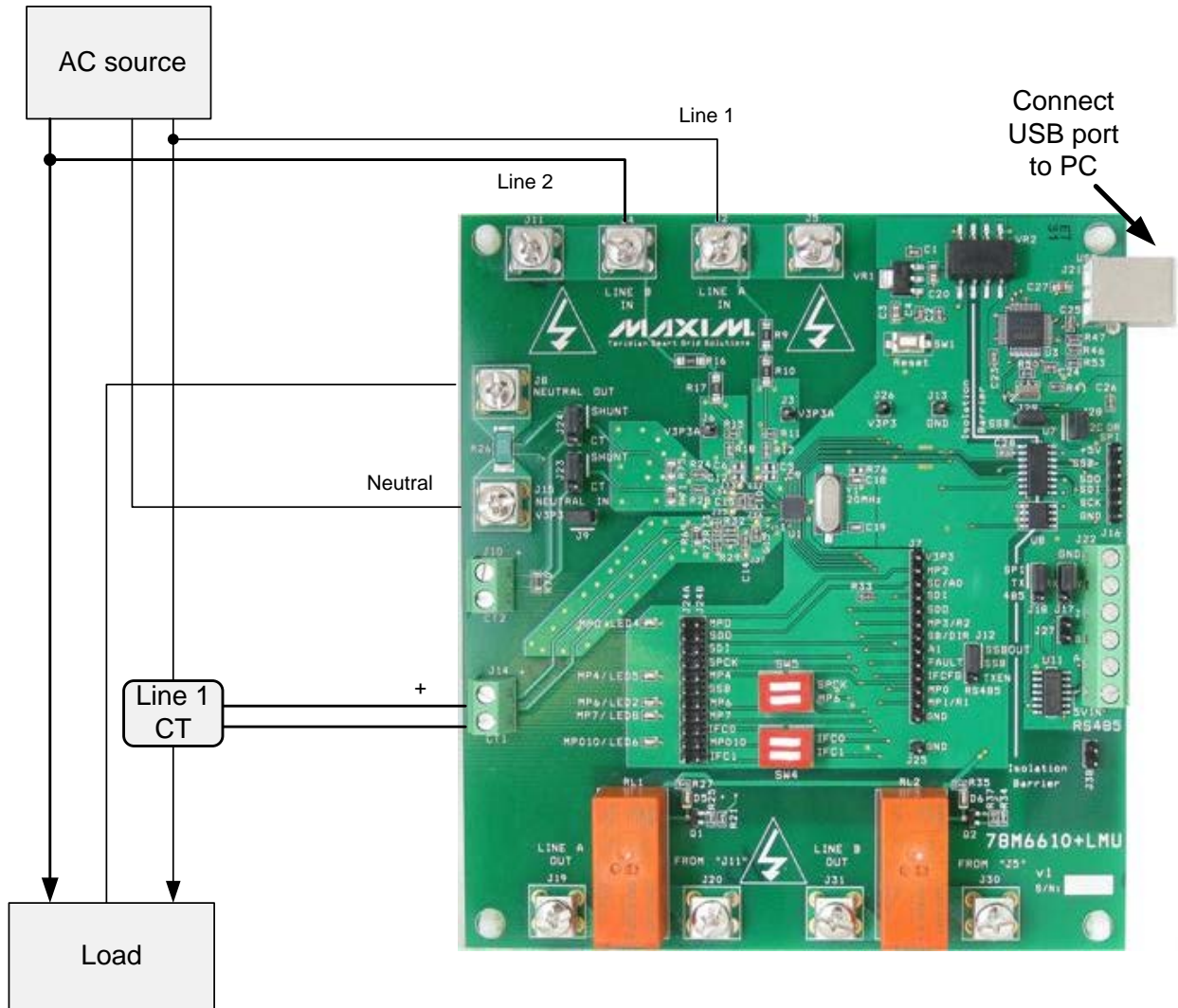

1. Connect the AC source Neutral output to J15.
2. Connect J8 to Load's Neutral input.
3. Connect the AC source Line 1 output to J2 and to Load's Line 1 input.
4. Feed Line 1 through the CT.
5. Connect Line 1 CT's secondary to J14 (burden resistor).
6. Connect the AC source Line 2 output to J4 and the Load's Line 2 input.

### 6.1.1 Jumper Position Changes

Move J23 and J24 jumpers to position CT to use CT2 and remove jumper at J9.

#### J23 Jumper Description

J23 Pins	Description	Jumper
1/2	Connect J15 SHUNT to 78M6610+LMU Sensor Slot 1	Installed
2/3	Connect J10 CT2+ to 78M6610+LMU Sensor Slot 1	-

#### J24 Jumper Description

J24 Pins	Description	Jumper
1/2	Connects J8 SHUNT to 78M6610+LMU Sensor Slot 1	Installed
2/3	Connects J10 CT2- to 78M6610+LMU Sensor Slot 1	-

#### J9 Jumper Description

J9 Pins	Description	Jumper
1/2	Connect AC Neutral to V3P3A (chip reference)	Installed

### 6.1.2 Device Configuration

Use the **Configuration** tab to map the sensors as shown in the table below. Re-enter the gain value for CT2 (located on bottom of board) into the S1\_GAIN register if needed.

Voltage			Current		
VA	S0	0	IA	0	S3
VB	0	S2	IB	-S1	-S3
VC	S0	-S2	Pre-Amp	1X S1	1X S3

**Note:** The values for VC and IB will not be displayed correctly on the **Power** tab of the provided GUI due to the increased full-scale values of VC and IB. Reported results for measurements derived from VC and IB will be one-half the expected magnitude.

## 6.2 Pseudo-Isolated Single-Phase Measurements Using CTs

In this diagram, the two voltage inputs are used to measure a single 2-wire interface for a high-impedance resistive isolation between AC and the 78M6610+LMU.

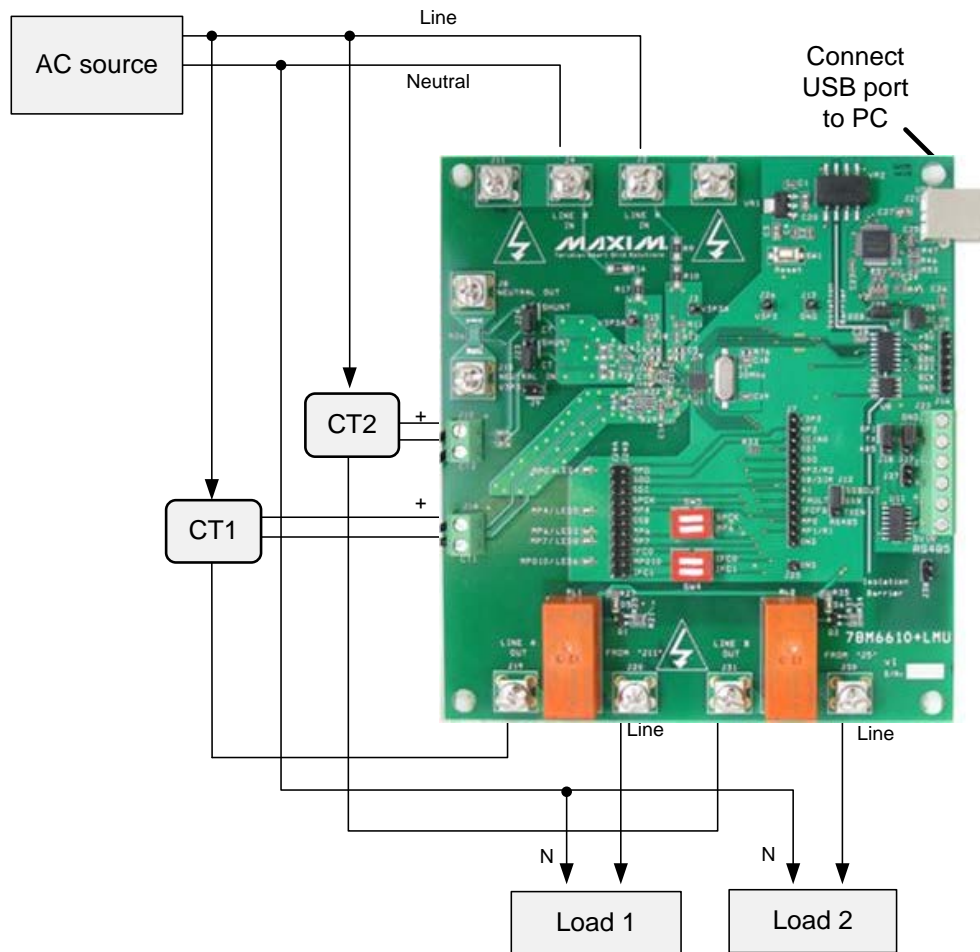

**Figure 3: 78M6610+LMU Evaluation Board Connections**

1. Connect the AC source Neutral to J4 and the load(s).
2. Connect the AC source Line to J2 and to J19 (Relay1) through the Line 1 CT.
3. Connect J20 (Relay1) to Line 1 load.
4. Connect Line 1 CT's secondary to J14 (burden resistor).

### If measuring a second load:

5. Connect the AC source Line to J31 (Relay2) through the Line 2 CT.
6. Connect J30 (Relay1) to Line 1 load.
7. Connect Line 2 CT's secondary to J10 (burden resistor).

### 6.2.1 Jumper Position Changes

Move J23 and J24 jumpers to position CT to use CT2 and remove jumper at J9.

#### J23 Jumper Description

J23 Pins	Description	Jumper
1/2	Connect J15 SHUNT to 78M6610+LMU Sensor Slot 1	-
2/3	Connect J10 CT2+ to 78M6610+LMU Sensor Slot 1	Installed

#### J24 Jumper Description

J24 Pins	Description	Jumper
1/2	Connects J8 SHUNT to 78M6610+LMU Sensor Slot 1	-
2/3	Connects J10 CT2- to 78M6610+LMU Sensor Slot 1	Installed

#### J9 Jumper Description

J9 Pins	Description	Jumper
1/2	Connect AC Neutral to V3P3A (chip reference)	-

### 6.2.2 Device Configuration

Use the **Configuration** tab to map the sensors as shown in the table below. Re-enter the gain value for CT2 (located on bottom of board) into the S1\_GAIN register if needed.

Voltage			Current		
VA	S0	-S2	IA	0	S3
VB	S0	-S2	IB	S1	0
VC			Pre-Amp	1X S1	1X S3

**Note:** The values will not be displayed correctly on the **Power** tab of the provided GUI due to the increased full-scale value of the voltages. Reported results for measurements will be one-half the expected magnitude.

## 7 Hardware Design Information

This section includes the schematics, bill of materials, and PCB layouts for the 78M6610+LMU EV board.

### 7.1 Board Schematics

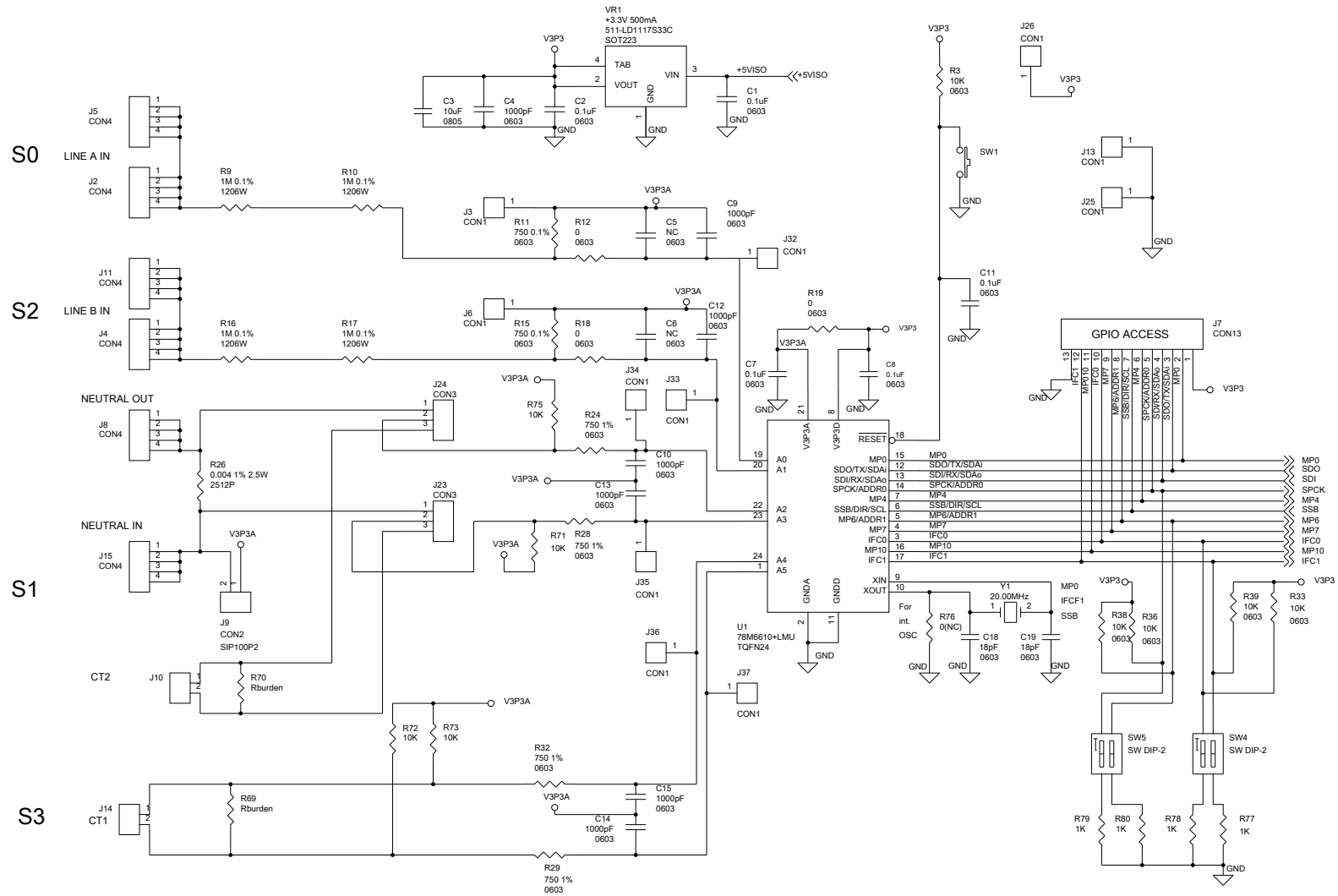

Figure 4: 78M6610+LMU Evaluation Board Electrical Schematic (1 of 4)



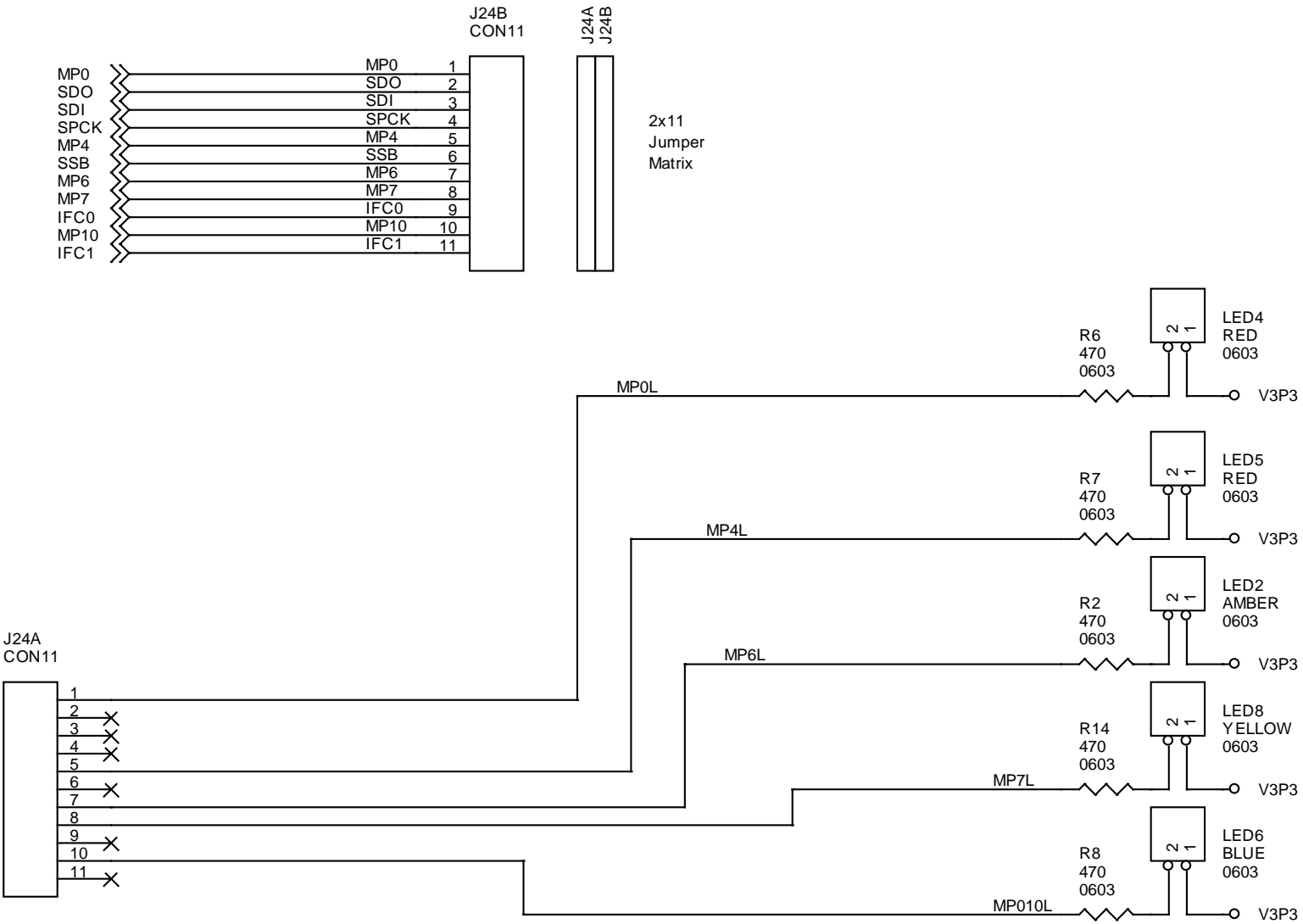

Figure 5: 78M6610+LMU Evaluation Board Electrical Schematic (2 of 4)

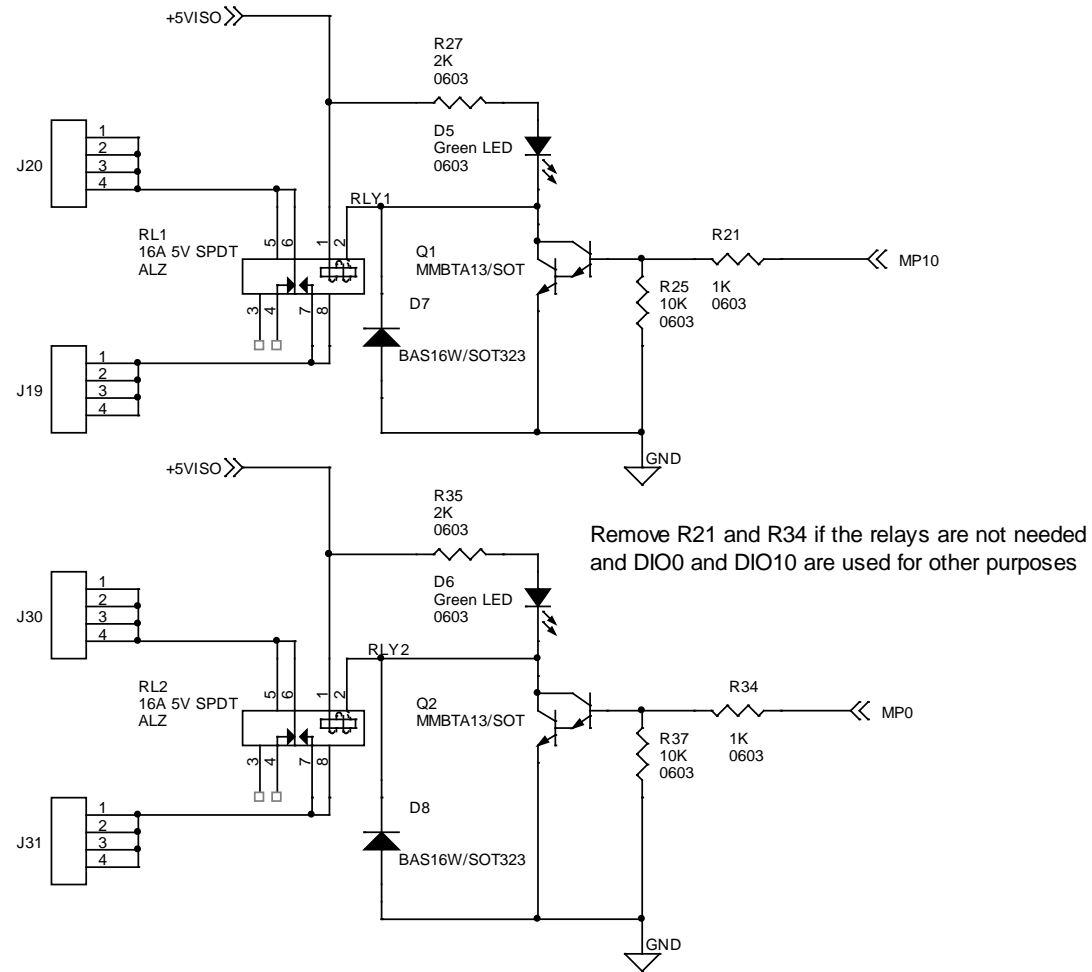

Figure 6: 78M6610+LMU Evaluation Board Electrical Schematic (3 of 4)

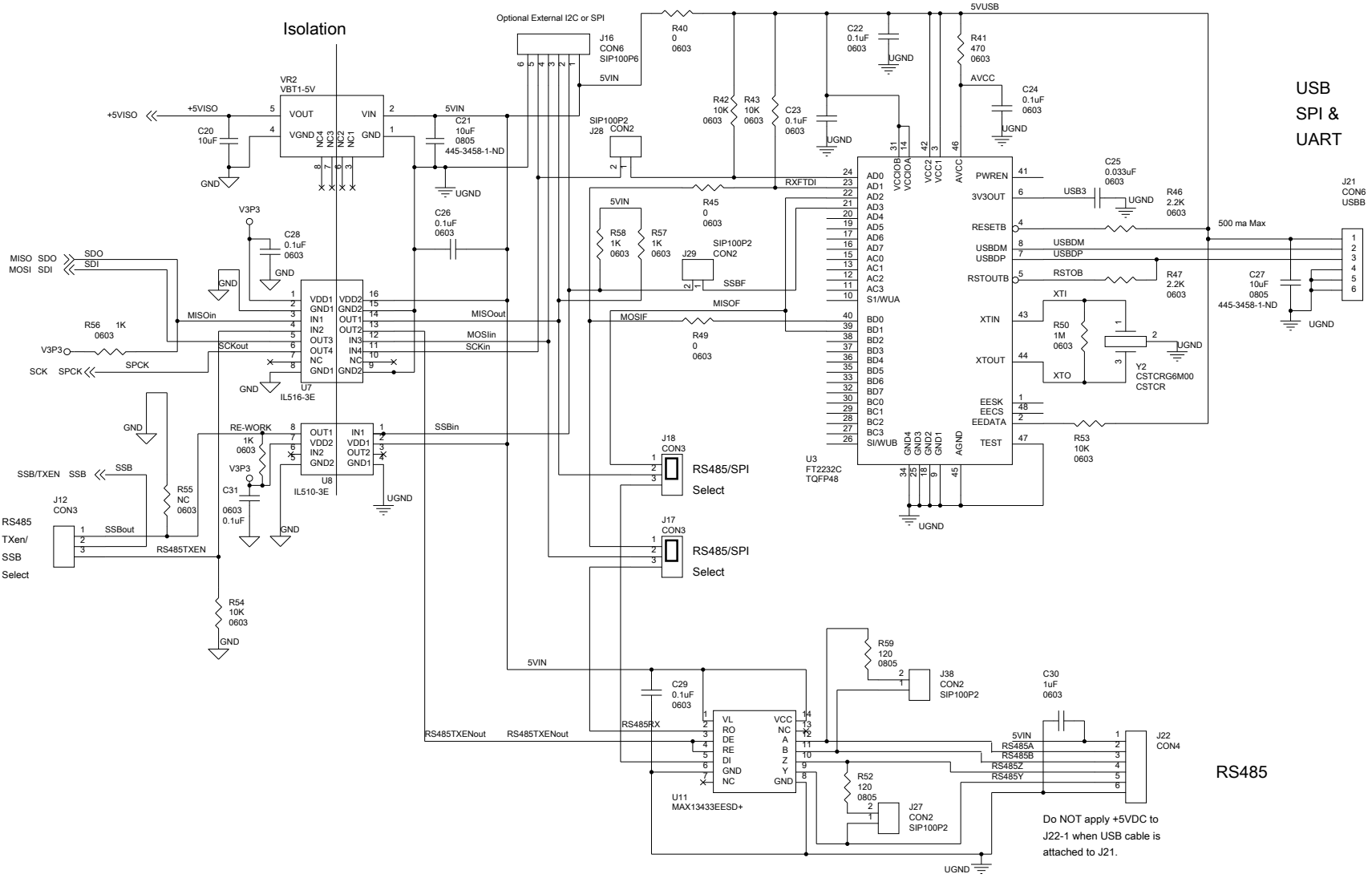

Figure 7: 78M6610+LMU Evaluation Board Electrical Schematic (4 of 4)

## 7.2 Bill of Materials

Item	Quantity	Reference	Part	PCB Footprint
1	12	C1,C2,C7,C8,C11,C22,C23,C24,C26,C28,C29,C31	0.1uF	0603
2	4	C3,C20,C21,C27	10uF	0805
3	7	C4,C9,C12,C10,C13,C14,C15	1000pF	0603
4	4	C5,C6	NC	0603
5	2	C18,C19	18pF	0603
6	1	C25	0.033uF	0603
7	1	C30	1uF	0603
8	2	D5,D6	Green LED	0603
9	2	D7,D8	BAS16W/SOT323	SOT-323 AC
10	10	J2,J4,J5,J8,J11,J15,J19,J20,J30,J31	CON4	STERM
11	5	J3,J6,J13,J25,J26	CON1	SIP100P1
12	1	J7	CON13	SIP100P13
13	5	J9,J27,J28,J29,J38	CON2	SIP100P2
14	2	J10,J14	TERM BLK 200-2	TERM BLK 200-2
15	5	J12,J17,J18,J23,J24	CON3	SIP100P3
16	1	J16	CON6	SIP100P6
17	1	J21	CON6	USBB
18	1	J22	CON4	TERM BLK 200-6
19	2	J24B,J24A	CON11	SIP100P11
20	6	J32,J33,J34,J35,J36,J37	CON1	sm pad
21	1	LED2	AMBER	0603
22	2	LED4,LED5	RED	0603
23	1	LED6	BLUE	0603
24	1	LED8	YELLOW	0603
25	2	Q1,Q2	MMBTA13/SOT	SOT-23
26	2	RL1,RL2	16A 5V SPDT	ALZ
27	6	R2,R6,R7,R8,R14,R41	470	0603
28	13	R3,R25,R33,R36,R37,R38,R39,R42,R43,R53,R54,R72,R73	10K	0603
29	4	R9,R10,R16,R17	1M 0.1%	1206W
30	2	R11,R15	750 0.1%	0603
31	6	R12,R18,R19,R40,R45,R49	0	0603
32	9	R21,R34,R56,R57,R58,R77,R78,R79,R80	1K	0603
33	4	R24,R28,R29,R32	750 1%	0603
34	1	R26	0.004 1% 2.5W	2512P
35	2	R27,R35	2K	0603
36	2	R46,R47	2.2K	0603

<b>Item</b>	<b>Quantity</b>	<b>Reference</b>	<b>Part</b>	<b>PCB Footprint</b>
37	1	R50	1M	0603
38	2	R52,R59	120	0805
39	2	R69,R70	Rburden	0805
40	2	R71,R75	10K	
41	2	R55,R76	0(NC)	0603
42	1	SW1	PUSHBUTTON	SMD (SMT) Tab
43	2	SW4,SW5	SW DIP-2	DIP4
44	1	U1	78M6610+LMU/B	TQFN24
45	1	U3	FT2232C	TQFP48
46	1	U7	IL516-3E	SO-16 NARROW
47	1	U8	IL612A	IL611A
48	1	U11	MAX13433EESD+	SO-14 NARROW
49	1	VR1	+3.3V 500mA	SOT223
50	1	VR2	VBT1-5V	VBT1
51	1	Y1	20.00MHz	ABLS
52	1	Y2	CSTCRG6M00	CSTCR

### 7.3 PCB Layout

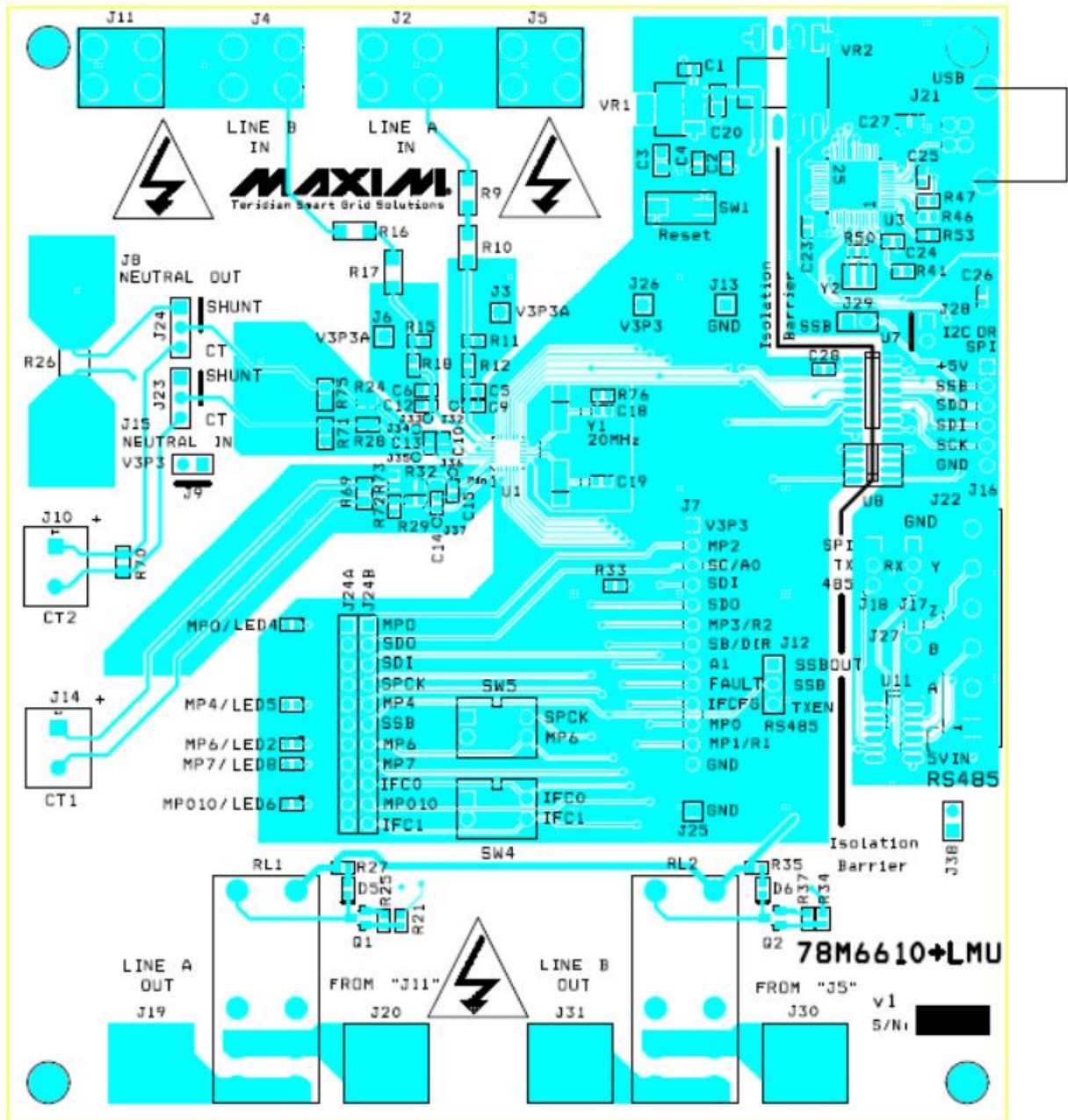

Figure 8: 78M6610+LMU Evaluation Board PCB Top View

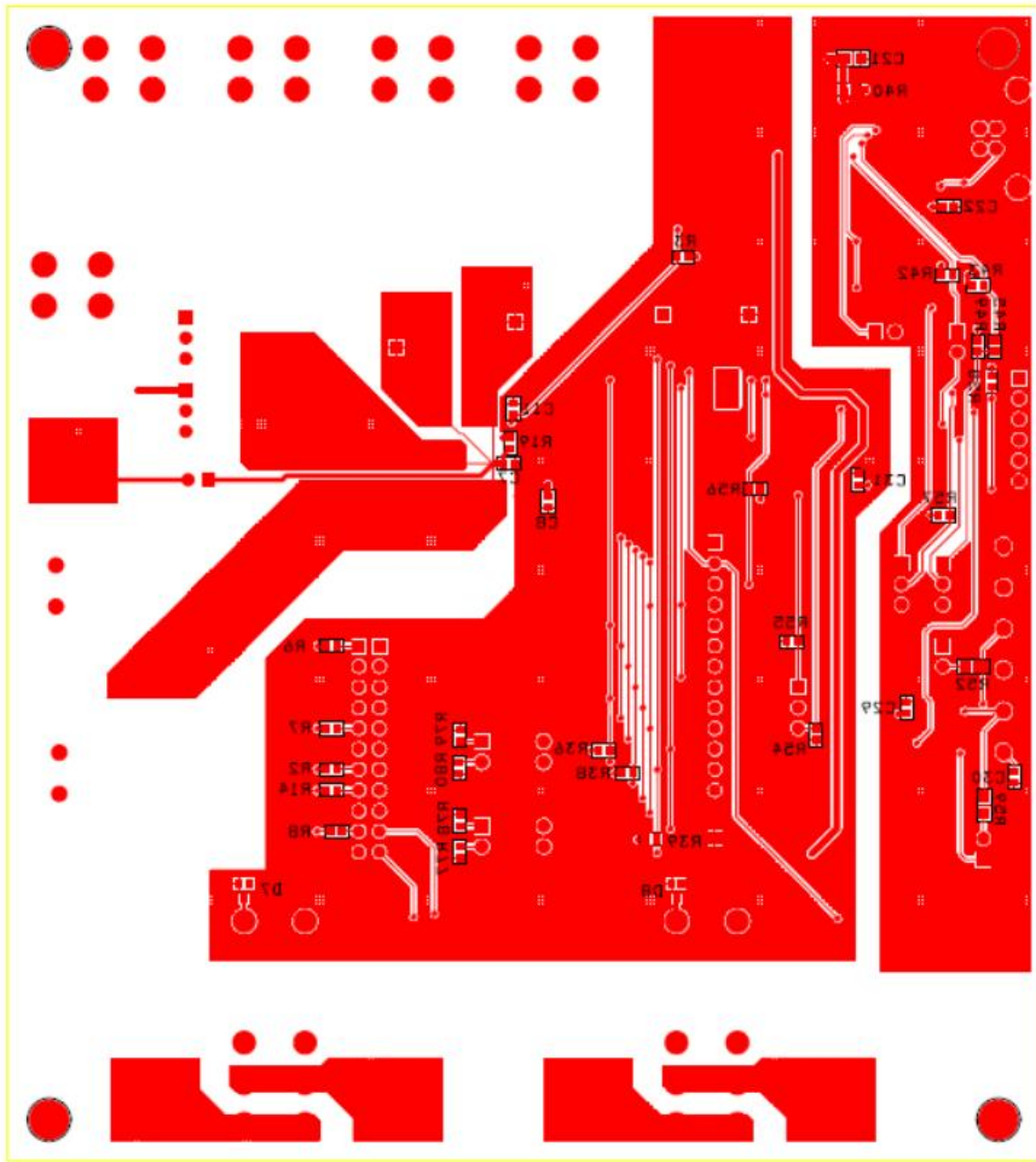

Figure 9: 78M6610+LMU Evaluation Board PCB Bottom View

## 8 Contact Information

For more information about Maxim Integrated products or to check the availability of the 78M6610+LMU, contact technical support at [www.maximintegrated.com/support](http://www.maximintegrated.com/support).

### Revision History

REVISION NUMBER	REVISION DATE	DESCRIPTION	PAGES CHANGED
0	2/13	Initial release	—
1	7/13	Updated ordering part number	4